



SMD Temperature Compensated Crystal Oscillator

TCXO 5032

Features

- Ceramic Package
- Wide Frequency Range
- RoHS compliant

Specifications		Option Codes
Frequency Range:		6.4 MHz ~ 40 MHz
Clipped Sine Wave	Output Level:	0.8 Volts [Peak-to-Peak] (min.)
	Load:	10 K Ohms // 10 pF \pm 10%
HCMOS	V _{High} :	0.9 V _{dd} (min.)
	V _{Low} :	0.1 V _{dd} (max.)
	Duty Cycle:	45% to 55%
	Rise/ Fall Time:	10 ns (max.) [20% to 80% of the waveform]
	Load:	15 pF \pm 10%
Supply Voltage, V _{dd} :		+2.5 V \pm 5% 2 +3.3 V \pm 5% 3 +5 V \pm 5% 5
Current Consumption:		3 mA (max.) for Clipped Sine Wave 20 mA (max.) for HCMOS
Supply Voltage Stability:		\pm 0.3 ppm (max.)
Load Stability:		\pm 0.3 ppm (max.)
Frequency Tolerance @ 25°C:		\pm 2 ppm (max.)
Operating Temperature Range and Temperature Stability:		Select from Table 1
Frequency Adjustment Option:		External Control Voltage V None (Fixed Frequency) N
Control Voltage Range:		1.5 V \pm 1.5 V (for +3.3 V)
Frequency Tuning Range:		\pm 5 ppm (min.)
Frequency Tuning Slope:		Positive
Linearity:		10% (max.)
Start-up Time:		10 ms (max.)
Aging @ +25°C:		\pm 1 ppm (max.) per year
Storage Temperature Range:		-55°C to +125°C



SMD Temperature Compensated Crystal Oscillator

Mechanical Specifications

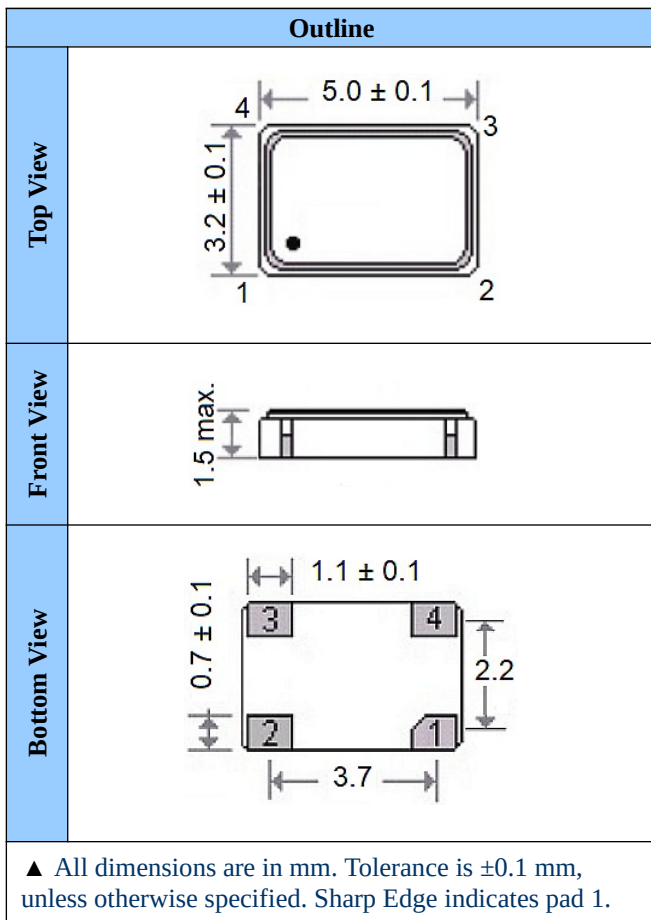

Table 1

OTR Codes	Stability Codes		X	Y	P	Q
	Temperature Stability		± 0.5 ppm	± 1 ppm	± 2 ppm	± 2.5 ppm
D	Operating Temperature Range (OTR)	-10°C to +60°C				
C		-20°C to +70°C				
H		-30°C to +85°C				
I		-40°C to +85°C				

■ Denotes Available □ Denotes not Available

Table 2
Typical SSB Phase Noise @ 10 MHz

10 Hz offset	-85 dBc/Hz
100 Hz offset	-115 dBc/Hz
1 KHz offset	-135 dBc/Hz
10 KHz offset	-140 dBc/Hz
100 KHz offset	-145 dBc/Hz

Ordering Information

Example

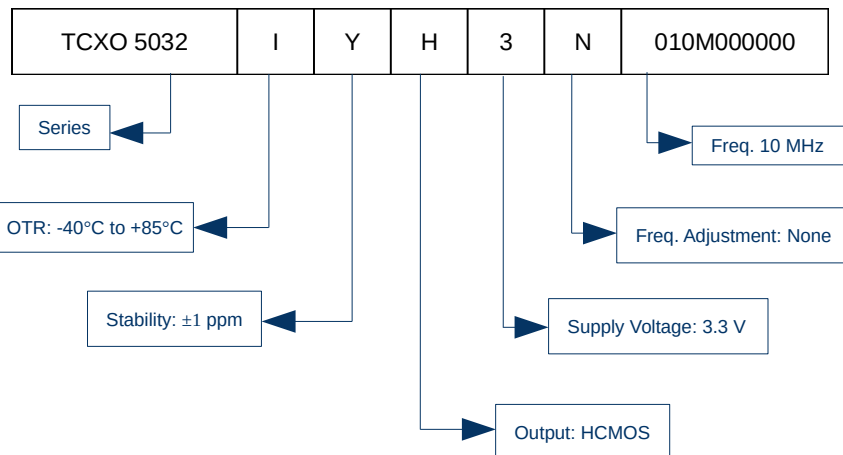

Pad Configuration:

Pad	Option N	Option V
1	No Connection	Control Voltage
2	Ground	Ground
3	Output	Output
4	Supply Voltage	Supply Voltage

Specifications subject to change without prior notice

Rev. Date: 20th December 2022

Note: Not all combination of options are available. Other specifications may be available upon request.

Doc. No.: AE/DS/PS/003

ISSUE 01

REVISION 01

Page 2 of 2

Andhra Electronics Pvt. Ltd.

Plot no. 34 & 35, IDA,
Kakinada-533 005
Andhra Pradesh, India
URL: www.andhraelec.com

Phone: +91 884 234 2203
Fax: +91 884 234 1145
e-mail: info@andhraelec.com